

Permanent Suspension Magnet

Specially applying for removing a small amount of tramp iron from thin layer and easy to handle materials transported by conveyor belt or chute

Provide new opportunity on refinement, purification and fast iron discharge for high standard material

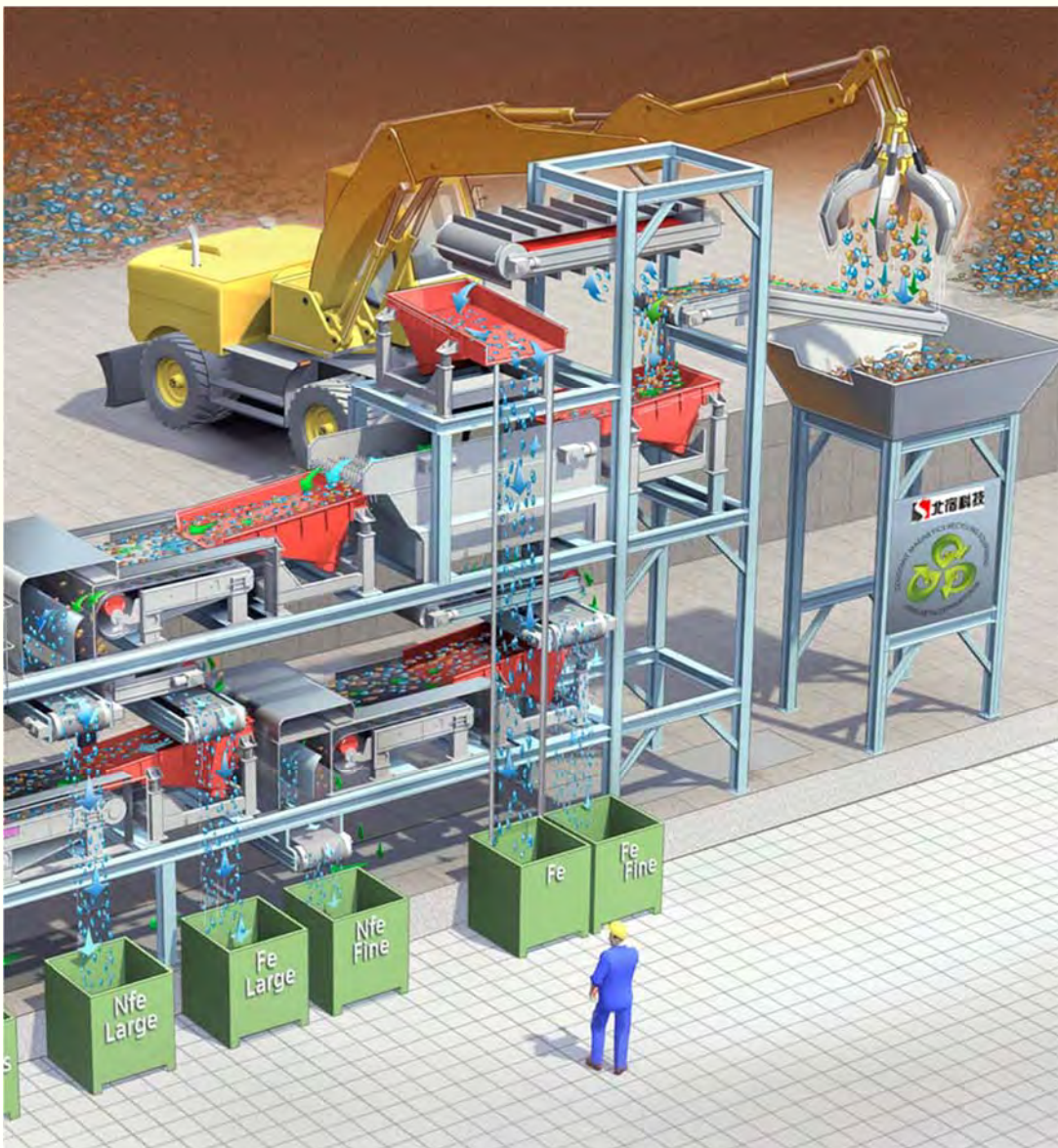

**HIGH EFFICIENCY AND HIGH QUALITY
MAGNETIC SEPARATION SOLUTIONS**

**Based on profound design capabilities, provide you with
more reasonable magnetic separation solutions**

Tianjin North Star Technology Co.,Ltd

Address: 10B, Taihu beiLi, 2 District, Sixiaotun Village,
Liangwangzhuang Town, Jinghai County, Tianjin,
P.R.China, 301617

Tel: +86-022-87987163

E-Mail: tjbeisu@163.com

Website: <http://tjbeisu.cn>

Company Profile

Tianjin North Star Technology Co., Ltd. is a professional equipment manufacturer dedicated to the magnetic separation industry. Relying on expertise in magnetic sorting and vibration conveying technology, it aims at designing and manufacturing high-performance equipment to provide the industry with high-performance and high-quality designed magnetic sorting, magnetic automation and vibration conveying equipment. With rich application experience in professional and technical fields, we can solve problem encountered in product processing, purification and quality review for enterprises.



Our mission

Provide efficient and practical customized products through technical innovation

Company vision

Become an quality supplier in the field of magnetic separation technology

Company strategy

Continuously develop and design new products according to industry need

Adopt expertise in magnetic separation technology, methods and materials

Continue to innovate and create various products that are user-friendly

Concentrate financial resources and the company's core resources for key projects

Experienced R&D technical team work together to create a better and safer world

Corporate organization structure oriented to common goals

Permanent Suspension Magnet

Permanent suspension magnet can couple with various of belt conveyors, vibration conveyors or chute to remove tramp iron from moving materials to purify materials, purification material and protect downstream equipment of next step.

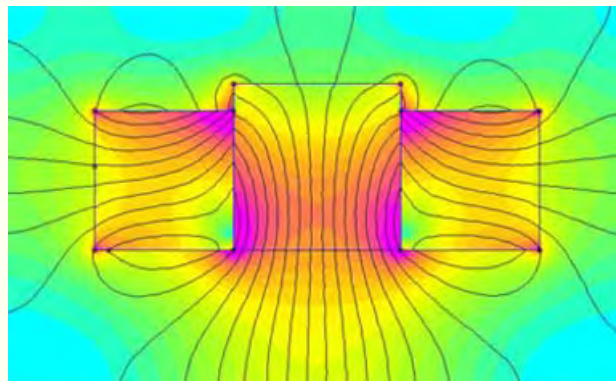

Design principle

The suspended permanent magnetic separator have a strong magnetic field composed of a ferrite magnet with high coercive force and high remanence, or a ferrite + neodymium iron boron rare earth magnet. No power, no energy consumption.

Characteristics and advantages

- ◇ Unique magnetic circuit design, large magnetic force action area and deep magnetic field strength
- ◇ Demagnetization rate doesn't exceed 1% within 10 years under harsh environment
- ◇ Its belt has automatic correction function. Suitable for harsh environments
- ◇ Continuous and automatic absorption of ferromagnetic materials and ensure long-term trouble-free operation
- ◇ No power excitation, no heat generation, no cooling required
- ◇ Compact and reasonable structure, easy installation
- ◇ Small upper space required for installation



Permanent Suspension Magnet

Optional configuration

Clean method: manual-cleaning or self-cleaning

Installation method: right on head pulley or across the belt

Box material: stainless steel plate or manganese steel base plate can be optional

Optional dust cover, zero switch, deviation switch, etc.

Optional various belts such as anti-static, wear-resistant, high-temperature belts, etc.

Optional explosion-proof and non-explosion-proof drive motors

Variable of magnetic field intensity can match customer requirement

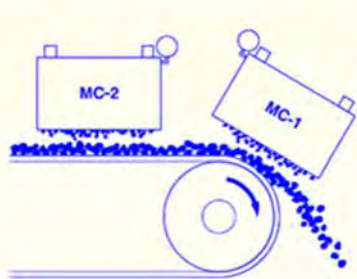

Manually Cleaning Position
MC-1 and MC-2

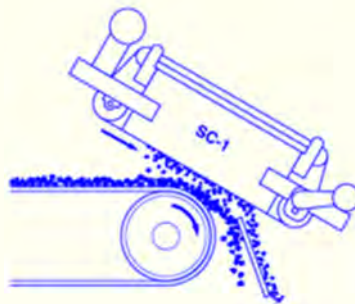

Automatic Cleaning Position
SC-1

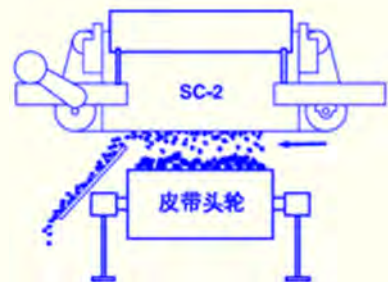

Automatic Cleaning Position
SC-2

Application

Protect crushers, grinders and other mechanical equipment safe and normally operation in conveyor systems. At the same time effectively prevent large and long iron objects from scratching the conveyor belt.

Application Industry

Metallurgy, mines, coal preparation plant, power station, ceramics, glass, cement, building materials, chemicals, food and feed



Permanent Suspension Magnet

Manual cleaning and tilting installation series

Manual cleaning type-Permanent Suspension Magnet requires manually clean accumulated ferromagnetic impurity and artificial labor intensity relatively larger. So we recommend use them to deal with where there is a small amount of ferromagnetic material occasionally.

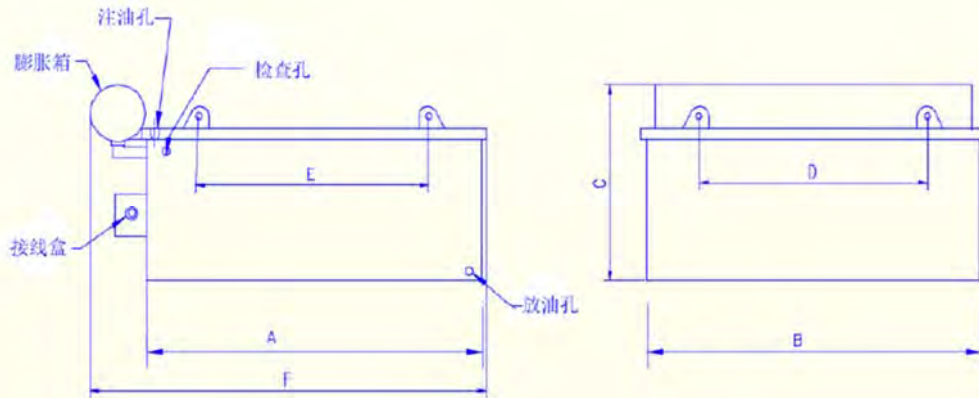

Specification	Main Dimension (mm)						Belt Width(mm)	h(mm)	H@ h (mt)	Excitation Power (kw)	Weight (kg)
	A	B	C	D	E	F					
RCDE-4-1	610	610	462	380	380	753	450	127	> 70	1.65	275
RCDE-6A-1	760	760	490	530	530	905	610	150	> 70	2.4	480
RCDE-6B-1	760	760	610	530	530	950	610	150	> 70	2.7	520
RCDE-7A-1	915	915	630	685	685	1150	760	180	> 70	3.6	735
RCDE-7B-1	915	915	680	685	685	1150	760	200	> 70	3.8	825
RCDE-9A-1	1070	1070	730	735	735	1300	915	200	> 70	4.8	1130
RCDE-9B-1	1070	1070	755	735	735	1300	915	250	> 70	4.9	1240
RCDE-9C-1	1070	1070	780	735	735	1300	915	250	> 70	5.1	1375
RCDE-10A-1	1220	1220	780	890	890	1450	1067	300	> 70	6.2	1780
RCDE-10B-1	1220	1220	805	890	890	1450	1067	300	> 70	6.3	1890
RCDE-10C-1	1220	1220	855	890	890	1450	1067	350	> 70	6.6	2175
RCDE-12A-1	1370	1370	855	1040	1040	1605	1220	350	> 70	7.9	2630
RCDE-12B-1	1370	1370	950	1040	1040	1605	1220	350	> 70	8.2	2910
RCDE-13A-1	1525	1525	950	1190	1190	1800	1370	400	> 70	9.6	3485
RCDE-13B-1	1525	1525	1000	1190	1190	1800	1370	400	> 70	9.9	3730
RCDE-13C-1	1525	1525	1030	1190	1190	1800	1370	400	> 70	10.1	4090
RCDE-15A-1	1680	1680	1080	1345	1345	1980	1525	450	> 70	11.9	4990
RCDE-15B-1	1680	1680	1110	1345	1345	1980	1525	450	> 70	12.1	5360
RCDE-15C-1	1680	1680	1130	1345	1345	1980	1525	500	> 70	12.3	5710
RCDE-15A-1	1830	1830	1220	1500	1500	2180	1680	550	> 70	14.4	6955
RCDE-15B-1	1830	1830	1280	1500	1500	2180	1680	550	> 75	14.8	8030
RCDE-15C-1	1980	1980	1330	1650	1650	2330	1830	600	> 75	17.2	9780

Note: h: on behalf of rated suspension height; H: on behalf of magnetic field intensity on position of h;

Applicable belt velocity ≤ 4.5m/s, continuous-duty, Voltage 115V;

Permanent Suspension Magnet

Manual cleaning and horizontal installation series

Specification	Main Dimension (mm)						Belt Width(mm)	h(mm)	H@ h (mt)	Excitation Power (kw)	Weight (kg)
	A	B	C	D	E	F					
RCDE-4-2	610	610	462	375	375	753	450	127	> 70	1.65	275
RCDE-6A-2	760	760	490	525	525	905	610	150	> 70	2.4	480
RCDE-6B-2	760	760	610	525	525	950	610	150	> 70	2.7	520
RCDE-7A-2	915	915	630	678	678	1100	760	180	> 70	3.6	735
RCDE-7B-2	915	915	680	678	678	1100	760	200	> 70	3.8	825
RCDE-9A-2	1070	1070	730	722	722	1300	915	200	> 70	4.8	1130
RCDE-9B-2	1070	1070	755	722	722	1300	915	250	> 70	4.9	1240
RCDE-9C-2	1070	1070	780	722	722	1300	915	250	> 70	5.1	1375
RCDE-10A-2	1220	1220	780	875	875	1450	1067	300	> 70	6.2	1780
RCDE-10B-2	1220	1220	805	875	875	1450	1067	300	> 70	6.3	1890
RCDE-10C-2	1220	1220	855	875	875	1450	1067	350	> 70	6.6	2175
RCDE-12A-2	1370	1370	855	1027	1027	1605	1220	350	> 70	7.9	2630
RCDE-12B-2	1370	1370	950	1027	1027	1605	1220	350	> 70	8.2	2910
RCDE-13A-2	1525	1525	950	1175	1175	1800	1370	400	> 70	9.6	3485
RCDE-13B-2	1525	1525	1000	1175	1175	1800	1370	400	> 70	9.9	3730
RCDE-13C-2	1525	1525	1030	1175	1175	1800	1370	400	> 70	10.1	4090
RCDE-15A-2	1680	1680	1080	1327	1327	1980	1525	450	> 70	11.9	4990
RCDE-15B-2	1680	1680	1110	1327	1327	1980	1525	450	> 70	12.1	5360
RCDE-15C-2	1680	1680	1130	1327	1327	1980	1525	500	> 70	12.3	5710
RCDE-15A-2	1830	1830	1220	1480	1480	2180	1680	550	> 70	14.4	6955
RCDE-15B-2	1830	1830	1280	1480	1480	2180	1680	550	> 75	14.8	8030
RCDE-15C-2	1980	1980	1330	1632	1632	2330	1830	600	> 75	17.2	9780

Note: **h**: on behalf of rated suspension height; **H**: on behalf of magnetic field intensity on position of h;

Applicable belt velocity $\leq 4.5\text{m/s}$, continuous-duty, Voltage 115V;

Automatic cleaning and tilting installation series

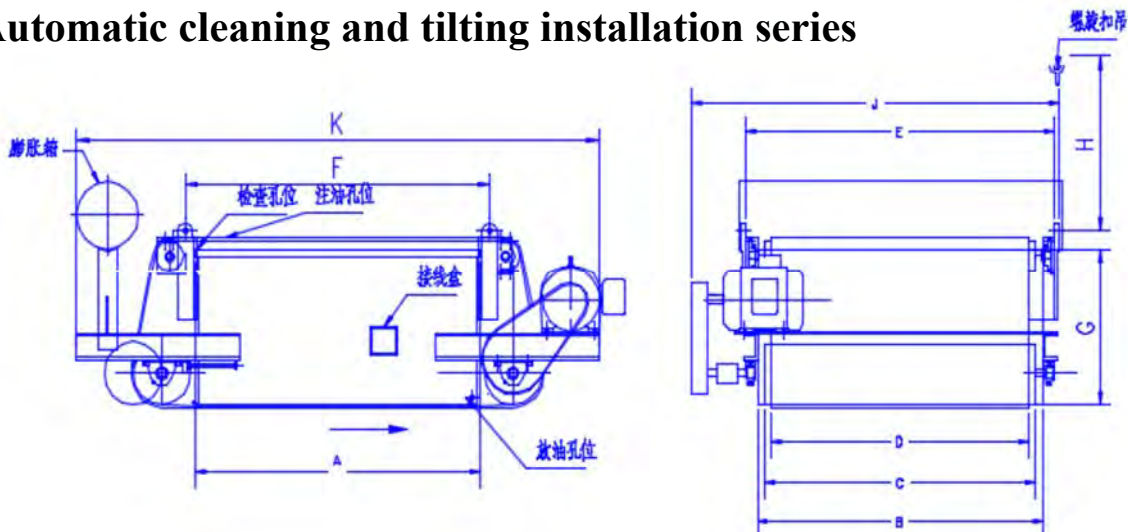

Permanent Suspension Magnet

Specification	Main Dimension (mm)										h(mm)	H@ h (mt)	Excitation Power (kw)	Voltage (V)	Driving power (kw)	Weight (kg)
	A	B	C	D	E	(F)	G	J	K	H						
RCDF-4-1	610	610	510	450	610	400	320	990	1820	600	150	> 70	1.65	115	1	500
RCDF-6A-1	760	760	660	610	760	550	350	1145	2210	600	170	> 70	2.4		1	750
RCDF-6B-1	760	760	660	610	760	550	420	1145	2324	600	180	> 70	2.7		1	885
RCDF-7A-1	915	915	815	760	915	705	450	1270	2540	630	200	> 70	3.6		1.5	1100
RCDF-7B-1	915	915	815	760	915	705	500	1270	2730	630	200	> 70	3.8		1.5	1300
RCDF-9A-1	1070	1070	965	915	1070	860	510	1370	2940	630	200	> 70	4.8		2	1670
RCDF-9B-1	1070	1070	965	915	1070	1190	525	1495	2140	660	250	> 70	4.9		2	1700
RCDF-9C-1	1070	1070	965	915	1070	1190	550	1495	2140	660	250	> 70	5.1		2	1850
RCDF-10A-1	1220	1220	1120	1067	1220	1340	550	1650	2460	660	300	> 70	6.2		3	2300
RCDF-10B-1	1220	1220	1120	1067	1220	1340	575	1650	2460	660	300	> 70	6.3		3	2400
RCDF-10C-1	1220	1220	1120	1067	1220	1340	625	1690	2460	660	350	> 70	6.6		3	2700
RCDF-12A-1	1370	1370	1295	1220	1370	1490	625	1750	2615	660	350	> 70	7.9		5	3200
RCDF-12B-1	1370	1370	1295	1220	1370	1490	680	1750	2615	660	350	> 70	8.2		5	3500
RCDF-13A-1	1525	1525	1450	1370	1525	1645	680	1960	2800	660	400	> 70	9.6		5	4100
RCDF-13B-1	1525	1525	1450	1370	1525	1645	720	1960	2800	730	400	> 70	9.9		5	4350
RCDF-13C-1	1525	1525	1450	1370	1525	1645	755	1960	2800	730	400	> 70	10.1		5	4700
RCDF-15A-1	1680	1680	1600	1525	1680	1800	780	2115	2950	730	450	> 70	11.9		5	5650
RCDF-15B-1	1680	1680	1600	1525	1680	1800	805	2115	2950	730	450	> 70	12.1		5	6000
RCDF-15C-1	1680	1680	1600	1525	1680	1840	830	2115	3000	730	500	> 70	12.3	5	6380	
RCDF-16A-1	1830	1830	1750	1680	1830	1990	880	2340	3050	730	550	> 70	14.4	230	7.5	7700
RCDF-16B-1	1830	1830	1750	1680	1830	1990	935	2340	3200	730	550	> 75	14.8		7.5	8820
RCDF-18-1	1980	1980	1900	1830	1980	2140	985	2500	3400	730	600	> 75	17.2		7.5	10600

Note: **h**: on behalf of rated suspension height; **H**: on behalf of magnetic field intensity on position of h;

Applicable belt velocity $\leq 4.5\text{m/s}$, continuous-duty

Automatic cleaning and horizontal installation series

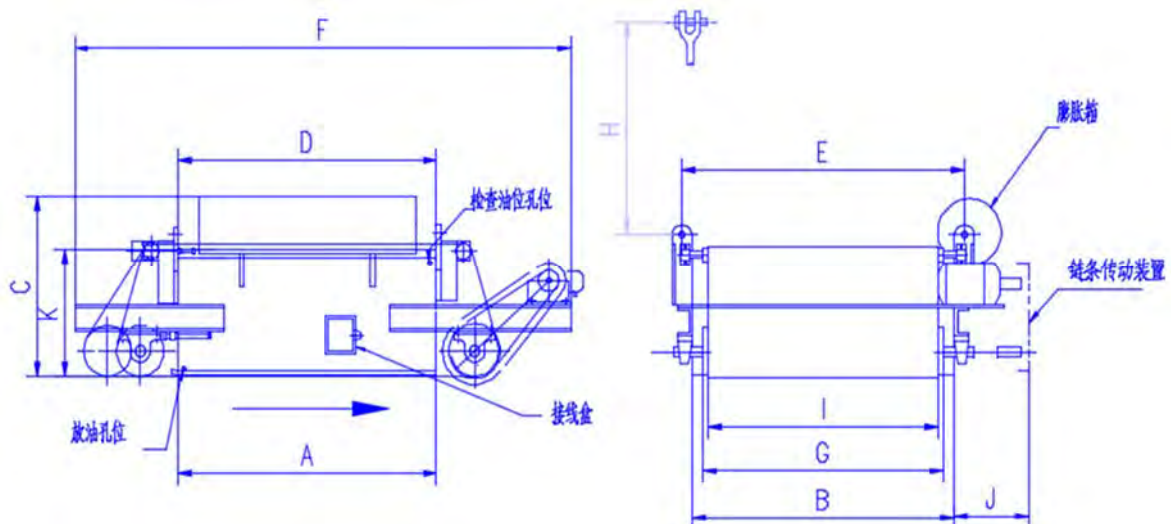

Permanent Suspension Magnet

Specification	Main Dimension (mm)											h(mm)	H@ h (mt)	Excitation Power	Voltage	Driving power	Weight
	A	B	C	D	E	F	G	H	I	J	K			(kw)	(V)	(kw)	(kg)
RCDF-4-2	610	610	600	610	815	1920	508	600	450	305	320	150	> 70	1.65		1	500
RCDF-6A-2	760	760	600	760	965	2120	660	600	610	305	350	170	> 70	2.4		1	750
RCDF-6B-2	760	760	590	760	965	2170	660	590	610	305	420	180	> 70	2.7		1	885
RCDF-7A-2	915	915	630	915	1120	2450	813	630	760	330	450	200	> 70	3.6		1.5	1100
RCDF-7B-2	915	915	630	915	1120	2650	813	630	760	280	500	200	> 70	3.8		1.5	1300
RCDF-9A-2	1070	1070	630	1070	1270	2830	965	630	915	330	500	200	> 70	4.8		2	1670
RCDF-9B-2	1070	1070	740	1070	1150	2150	965	740	915	330	525	250	> 70	4.9		2	1700
RCDF-9C-2	1070	1070	660	1070	1150	2150	965	660	915	330	550	250	> 70	5.1		2	1850
RCDF-10A-2	1220	1220	740	1220	1300	2315	1118	740	1067	330	550	300	> 70	6.2		3	2300
RCDF-10B-2	1220	1220	740	1220	1300	2315	1118	740	1067	330	575	300	> 70	6.3		3	2400
RCDF-10C-2	1220	1220	660	1220	1325	2315	1118	660	1067	330	625	350	> 70	6.6		3	2700
RCDF-12A-2	1370	1370	740	1370	1450	2465	1295	740	1220	360	625	350	> 70	7.9		5	3200
RCDF-12B-2	1370	1370	740	1370	1450	2465	1295	740	1220	330	680	350	> 70	8.2		5	3500
RCDF-13A-2	1525	1525	660	1525	1600	2600	1448	660	1370	330	680	400	> 70	9.6		5	4100
RCDF-13B-2	1525	1525	730	1525	1600	2600	1448	730	1370	330	720	400	> 70	9.9		5	4350
RCDF-13C-2	1525	1525	730	1525	1600	2600	1448	730	1370	330	755	400	> 70	10.1	115	5	4700
RCDF-15A-2	1680	1680	830	1680	1780	2760	1600	830	1525	330	780	450	> 70	11.9		5	5650
RCDF-15B-2	1680	1680	730	1680	1755	2760	1600	730	1525	330	805	450	> 70	12.1		5	6000
RCDF-15C-2	1680	1680	750	1680	1755	2780	1600	750	1525	330	830	500	> 70	12.3		5	6360
RCDF-16A-2	1830	1830	830	1830	1900	3050	1753	830	1680	330	875	550	> 70	14.4		7.5	7700
RCDF-16B-2	1830	1830	830	1830	1900	3000	1753	830	1680	330	935	550	> 75	14.8		7.5	8820
RCDF-18-2	1980	1980	915	1980	2085	3200	1905	915	1830	410	985	600	> 75	17.2	230	7.5	10600

Note: **h**: on behalf of rated suspension height; **H**: on behalf of magnetic field intensity on position of h;

Applicable belt velocity ≤ 4.5m/s, continuous-duty

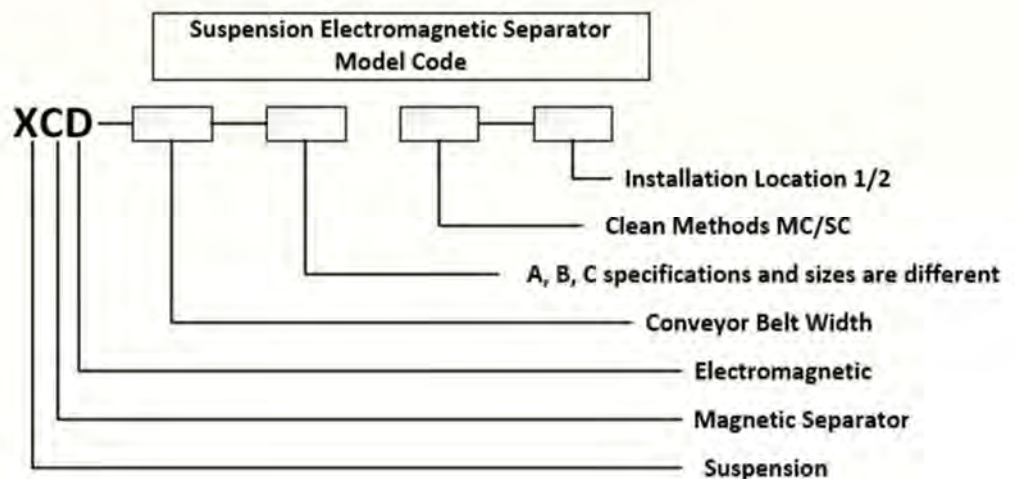

Permanent Suspension Magnet

Please refer to the track selection according to the walking track of suspension magnet.

1. DX Electric walking device

1.1 DX-2 ● Z Electric double-track combination walking

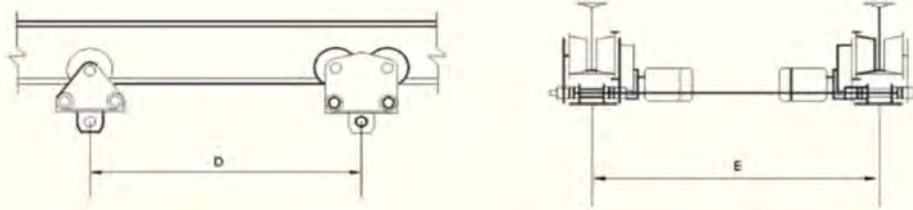

Mainly Technical Specification

Model	DX-2 ● Z-2	DX-2 ● Z-4	DX-2 ● Z-6	DX-2 ● Z-10	DX-2 ● Z-20
Allowable Load (t)	2	4	6	10	20
Motor Power (kw)	0.4x2	0.4x2	0.4x2	0.4x2	0.4x2
Running velocity (m/min)	10	10	10	10	10
I-rail type /Gb706-88	16a-28b	25a-63c			

1.2 DX-1 ● Z Electric single-track combination walking

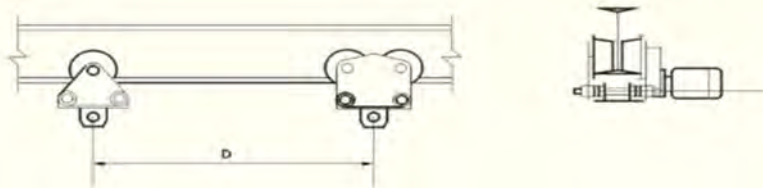

1.3 DX-1 ● 1 Electric single-track walking

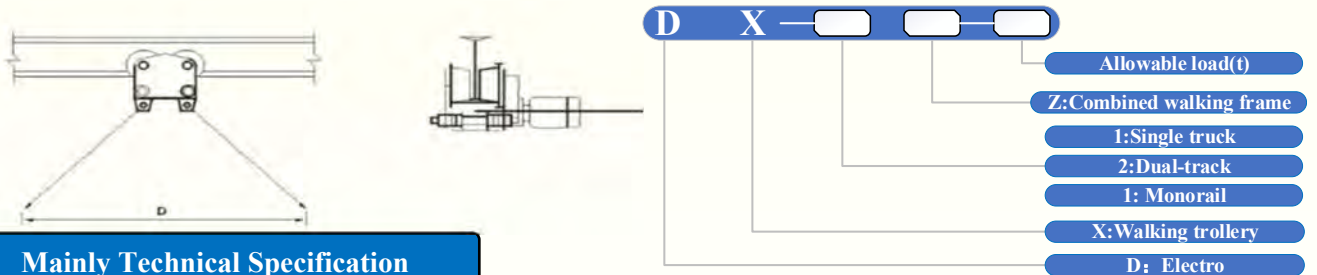

Mainly Technical Specification

Item	Model	DX-1 ● Z-1	DX-1 ● Z-3	DX-1 ● Z-5	DX-1 ● Z-10
		DX-1 ● 1-1	DX-1 ● 1-3	DX-1 ● 1-5	
Allowable Load (t)		1	3	5	10
Motor Power (kw)		0.4	0.4	0.8	0.8
Running velocity (m/min)		10	10	10	10
I-rail type /Gb706-88		16a-28b	25a-63c		

Note: D, E- Hanging dimension of suspension magnet.

※ Trolley running speed have 20m/min grade which is available for on-site selection.

Permanent Suspension Magnet

2. SDX Manual walking device

2.1 SDX-2 • Z Manual double-track combination walking

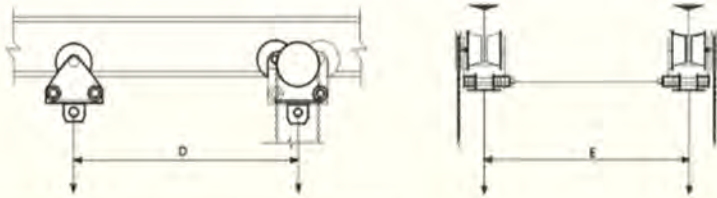

Mainly Technical Specification

Item \ Parameter	Model	SDX-2 • Z-2	SDX-2 • Z-4	SDX-2 • Z-6	SDX-2 • Z-10	SDX-2 • Z-20
Allowable Load (t)		2	4	6	10	(20)
Power		Manual				
Running velocity		Manual control				
I-rail type /Gb706-88		16a-28b	20a-32c	25a-63c		

(only for reference)

2.2 SDX-1 • Z Manual single-track combination walking

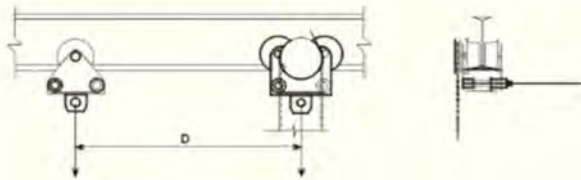

2.3 SDX-1 • 1 Manual single-track walking

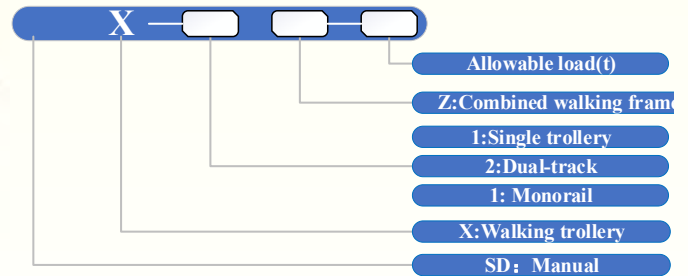
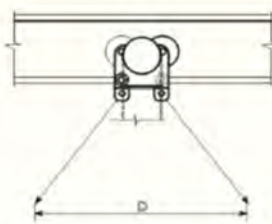

Mainly Technical Specification

Item \ Parameter	Model	SDX-1 • Z-1 SDX-1 • 1-1	SDX-1 • Z-3 SDX-1 • 1-3	SDX-1 • Z-5 SDX-1 • 1-5	SDX-1 • Z-10 SDX-1 • 1-10	SDX-1 • Z-20
Allowable Load (t)		1	3	5	(10)	(20)
Power		Manual				
Running velocity		Manual control				
I-rail type /Gb706-88		16a-28b	20a-32c	25a-63c		

Note:() is not the preferentially selected.

(only for reference)

Permanent Suspension Magnet

Hanging combination and type

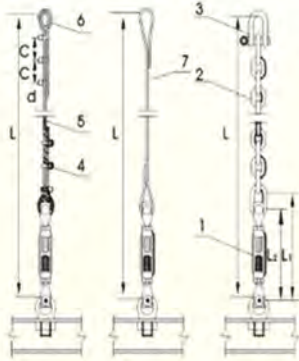

Wirerope Steel tie rode Sling

1. turnbuckle
2. Anchor Chain
3. Rigging Shackle
4. Rope cramp
5. Wirerope
6. Lantern ring
7. Steel tie rode

1. Steel rods are available for both opening (user self-welding) and sealing
2. If the user has special requirements, the screw buckle can not be selected according to the table. Which model to order should be specially marked.
3. Attention should be paid to the selection of wire rope hanging device:

- (1) Rope clamps must not be set up one positive and one negative setting on the wire rope
- (2) The U-bolt of the rope clamp must be buckled in from one side of the tail section. Then the clamp seat is buckled in from one side of the working section (see picture)
- (3) When connecting each end of the steel wire rope, the number and spacing of a set of rope clamps are shown in the following table
4. It is recommended to use wire rope slings first

Nominal size of rope clamp (mm) (Nominal diameter of wire rope d)	Minimum number of rope clamps in each group	Distance between rope clamps (c)
≤19	3	(6-7)·d
>19-32	4	

Mainly Technical Specification

Item Hanging weight (t)	Steel Wire Rope (GB8919-88)				Short Chain (GB5802-86)				Steel Tie Rod	Forged Shackles (GB/T10603-89)				Turnbuckle (GB561-65)			
	Rope Diameter r Ø	Lantern Ring (GB/T5971-86)	Rope Cramp (GB5976-86)	Hanging weight	d	p	w	Hanging weight (t)		Diameter (φ)	Specification			Adjustable distance		Hanging weight (t)	
	D	Nominal Diameter	Specification	t							M	W	S	Hanging weight (t)	Type A (Type B)		Shortest L ₂
0.5	9	10	10	4	9	27	30	2	12	M12	12	25	0.63	A0.9 M14 d1=14 b=18	294	434	0.9
										M14	14	28	0.8				
1	9	10	10	4	9	27	30	2	16	M14	14	28	0.8	A1.2 M16 d1=b=22	356	524	1.25
										M16	16	31.5	1				
2	12	12	12	7.5	12.5	38	41	4	20	M20	20	40	1.6	A2.1 M20 d1=20 b=27	418	603	2.1
										M22	22	45	2				
3	12	12	12	7.5	12.5	38	41	4	22	M24	24	50	2.5	A3.5 M24 d1=26 b=32	507	719	3.5
										M30	30	56	3.2				
4	16	16	16	13	16	48	52	8	26	M30	30	56	3.2	A4.5 M27 d1=30 b=36	545	757	4.5
										M33	33	63	4				
5	16	16	16	13	16	48	52	8	30	M36	36	71	5	B6 M33 d1=32 b=40	633	881	6
										M39	39	80	6.3				
7	22	22	22	25	18	54	59	15	35	M39	39	80	6.3	B7.5 M36 d1=36 b=44	652	900	7.5
										M45	45	90	8				
10	22	22	22	25	20	60	65	20	40	M52	52	100	10	B11 M45 d1=45 b=52	762	1027	9.5
										M56	56	112	12.5				
15	24	24	24	30	20	60	65	20	45	M56	56	112	12.5	B14 M48 d1=50 b=58	843	1133	14
										M64	64	125	16				
Note	1. Each suspension magnet shall be equipped with 4 pieces of steel wire rope. The total length of each rope shall be ordered by user according to the field space. 2. The selection of each steel wire rope shall be according to the weight of suspension magnet and the weight of hanging device.																